

Preinstallation Manual
AVIA 355/355-X Laser

This document is copyrighted with all rights reserved. Under the copyright laws, this document may not be copied in whole or in part or reproduced in any other media without the express written permission of Coherent, Inc. Permitted copies must carry the same proprietary and copyright notices as were affixed to the original. This exception does not allow copies to be made for others, whether or not sold, but all the material purchased may be sold, given or loaned to another person. Under the law, copying includes translation into another language.

Coherent, the Coherent Logo and AVIA are registered trademarks of Coherent, Inc.

This product is sold by Coherent pursuant to a limited sublicense under U.S. Patent No. Re 34,729. The rights which customers of Coherent receive through purchase of this product are restricted, and exclude any right to use the product in the telecommunications field.

Every effort has been made to ensure that the data given in this document is accurate. The information, figures, tables, specifications and schematics contained herein are subject to change without notice. Coherent makes no warranty or representation, either expressed or implied with respect to this document. In no event will Coherent be liable for any direct, indirect, special, incidental or consequential damages resulting from any defects in its documentation.

Technical Support

In the US:

Should you experience any difficulties with your laser or need any technical information, please visit our web site www.Coherent.com. Additional support can be obtained by contacting our Technical Support Hotline at 800-367-7890 (408-764-4557 outside the U.S.) or E-mail (clg.tech.services@Coherent.com). Telephone coverage is available Monday through Friday (except U.S. holidays and company shutdowns).

If you call outside our office hours, your call will be taken by our answering system and will be returned when the office reopens.

If there are technical difficulties with your laser that cannot be resolved by support mechanisms outlined above, please E-mail or telephone Coherent Technical Support with a description of the problem and the corrective steps attempted. When communicating with our Technical Support Group, via the web or telephone, the model and Laser Head serial number of your laser system will be required by the Support Engineer responding to your request.

Outside the US:

If you are located outside the US visit our web site for technical assistance or contact, by phone, our local Service Representative. Representative phone numbers and addresses can be found on the Coherent web site, www.Coherent.com.

Coherent provides telephone and web technical assistance as a service to its customers and assumes no liability thereby for any injury or damage that may occur contemporaneous with such services. These support services do not affect, under any circumstances, the terms of any warranty agreement between Coherent and the buyer. Operation of any Coherent laser with any of its interlocks defeated is always at the operator's own risk.

TABLE OF CONTENTS

Preface	v
U.S. Export Control Laws Compliance	v
Symbols Used in This Manual and on the Laser System	vi
Installation	1
Introduction.....	1
Installation	1
Receiving and Inspection.....	1
External Interlock	1
Shutter Interlock	2
Installing the Power Supply.....	2
Installing the Water Chiller.....	2
Installing the Laser Head	3
External Equipment	4
Umbilical Bend Radius.....	5
Installation Procedures.....	5
External Computer Control.....	17
AVIA Computer Interface	17
RS-232 Command Language.....	17
RS-232 Command Syntax	17
ECHO Mode	18
PROMPT Mode	18
? or Print.....	18
Characters = or :.....	18
RS-232 Port Configuration	19
Setting the Baud Rate	20
Instruction Set.....	20

LIST OF ILLUSTRATIONS

1. Interconnection Diagram	4
2. Power Supply Dimensions (with Rack Mount - Optional).....	7
3. AVIA Laser Head Dimensions	8
4. AVIA External Interface.....	15
5. RS-232 Pin Configuration	19

LIST OF TABLES

1.	Utility Requirements.....	6
2.	Environmental Requirements	6
3.	Dimensions and Weights	6
4.	EXTERNAL INTERLOCK/CHILLER Connector Pinouts	12
5.	EXTERNAL INTERFACE Connector Pinouts.....	13
6.	BNC Connectors	14
7.	Suggested Mating Connectors to Interface with the AVIA Laser System	15
8.	Maximum Input Voltage/Current	16
9.	Response from Laser after Receiving Instruction.....	18
10.	RS-232 Port Description.....	19
11.	RS-232 Commands	20
12.	RS-232 Queries.....	24

Preface

This manual contains preinstallation information for the AVIA 355/355-X Diode-Pumped Laser.



Read the operator's manual carefully before operating the laser for the first time. Special attention should be given to Section One, Laser Safety, within the operator's manual that describes safety features built into the laser.

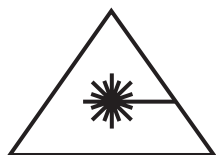

Use of controls or adjustments or performance of procedures other than those specified in this manual may result in hazardous radiation exposure.



Use of the system in a manner other than that described herein may impair the protection provided by the system.

U.S. Export Control Laws Compliance

It is the policy of Coherent to comply strictly with U.S. export control laws.

Export and re-export of lasers manufactured by Coherent are subject to U.S. Export Administration Regulations, which are administered by the Commerce Department. In addition, shipments of certain components are regulated by the State Department under the International Traffic in Arms Regulations.

The applicable restrictions vary depending on the specific product involved and its destination. In some cases, U.S. law requires that U.S. Government approval be obtained prior to resale, export or re-export of certain articles. When there is uncertainty about the obligations imposed by U.S. law, clarification should be obtained from Coherent or an appropriate U.S. Government agency.

Symbols Used in This Manual and on the Laser System

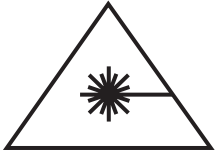

This symbol is intended to alert the operator to the danger of exposure to hazardous visible laser radiation.



This symbol is intended to emphasize the presence of important operating instructions.

INSTALLATION

Introduction

The purpose of this document is to assist the user in establishing a suitable location and operating environment for optimum AVIA 355/355-X performance.

Installation

Initial installation should be performed by an authorized Coherent service engineer or by Coherent trained personnel.

Receiving and Inspection

Inspect shipping containers for signs of rough handling or damage. Indicate any such signs on the bill of lading. Report any damage immediately to the shipping carrier and to Coherent Order Administration Department.



Retain shipping containers. The containers will be required if the system is returned to the factory for service. The containers may also be needed to support a shipping damage claim.

Coherent recommends that at least three people unpack and transport the AVIA 355. The power supply which weighs 85 pounds should be lifted by two people while the laser head which weighs 48 to 56 pounds can be lifted by the third person. The laser head and power supply are connected by the umbilical.

External Interlock

The system will not operate with the interlock open. An interlock connector is located on the power supply rear panel. The interlock status is monitored by the CPU. If the interlock is open, a message will be displayed of the power supply front panel.

An external interlock circuit can be connected to the laser system and wired to a door switch or access panel to provide additional operating safety. When the door is opened, the laser will shut down. The fault must be cleared and the diodes turned on to restart the laser.

To incorporate an external safety interlock circuit into the laser system, turn off the laser and remove the jumper from the interlock connector on the power supply rear panel. Attach a user furnished external interlock circuit to this connector. Any external interlock

circuit should be equivalent to a mechanical closure of the circuit. Under no circumstances should an external voltage or current source be connected to this circuit. External interlock circuitry should be isolated from all other electrical circuits or grounds.

Shutter Interlock

The shutter will not open unless the shutter interlock circuit is closed. If the shutter interlock circuit is opened while the laser is operating, it will cause the shutter to close but will not turn the laser off.

Installing the Power Supply

Locate the power supply in a convenient location, preferably away from heat producing sources. Ensure the cooling intake and exhaust are not blocked or obstructed.

In some cases, the power supply is shipped without a connector on the power cord. Each locality should inspect the power cord and install the proper connector if necessary. The connector should be installed in a properly grounded outlet with a maximum of 15 Ampere service for proper overcurrent and earth fault protection.

Installing the Laser Head

Mounting screws and pin/slot locations for laser head installation are shown on Figure 3. Four M8 or 3/8-16 screws are used to mount the laser head to the mounting surface.

Remove the shipping cover plate from the front bezel of the laser head before operating the laser.

The temperature of the laser head baseplate is monitored by the AVIA power supply and is displayed on the power supply front panel. The baseplate temperature is used to monitor the effectiveness of heat dissipation. Maximum heat dissipation through the baseplate is 65 Watts for the 355-3000, 80 Watts for the 355-4500, 110 Watts for the 355-7000, and 150 Watts for the 355-X. The surface to which the laser head is mounted must be thermally conductive and well heat sunk to the ambient air by means of its thermal mass or by forced air cooling. In most cases, the mounting surface and structure will be adequate to provide cooling for the laser head. However, if the mounting surface is not sufficient to conduct heat away, some form of cooling must be supplied. This could be in the form of fins with forced air cooling; or, a water cooled base structure. For air cooling the laser head, the maximum ambient air temperature is 35°C for the model 355-3000 and model 355-4500. It is recommended that the model 355-7000 be used with a water cooled base structure, available as an accessory. The model

355-X has a built in water-cooled base structure. In all cases the AVIA lasers will operate properly over a wide range of operating temperatures, but for maximum power and pointing stability the temperature of the base plate should vary no more than $\pm 2^{\circ}\text{C}$. The AVIA laser will shut down if the baseplate temperature exceeds 40°C .

External Equipment

Connection of optional user furnished external equipment is illustrated and described on Figure 1.

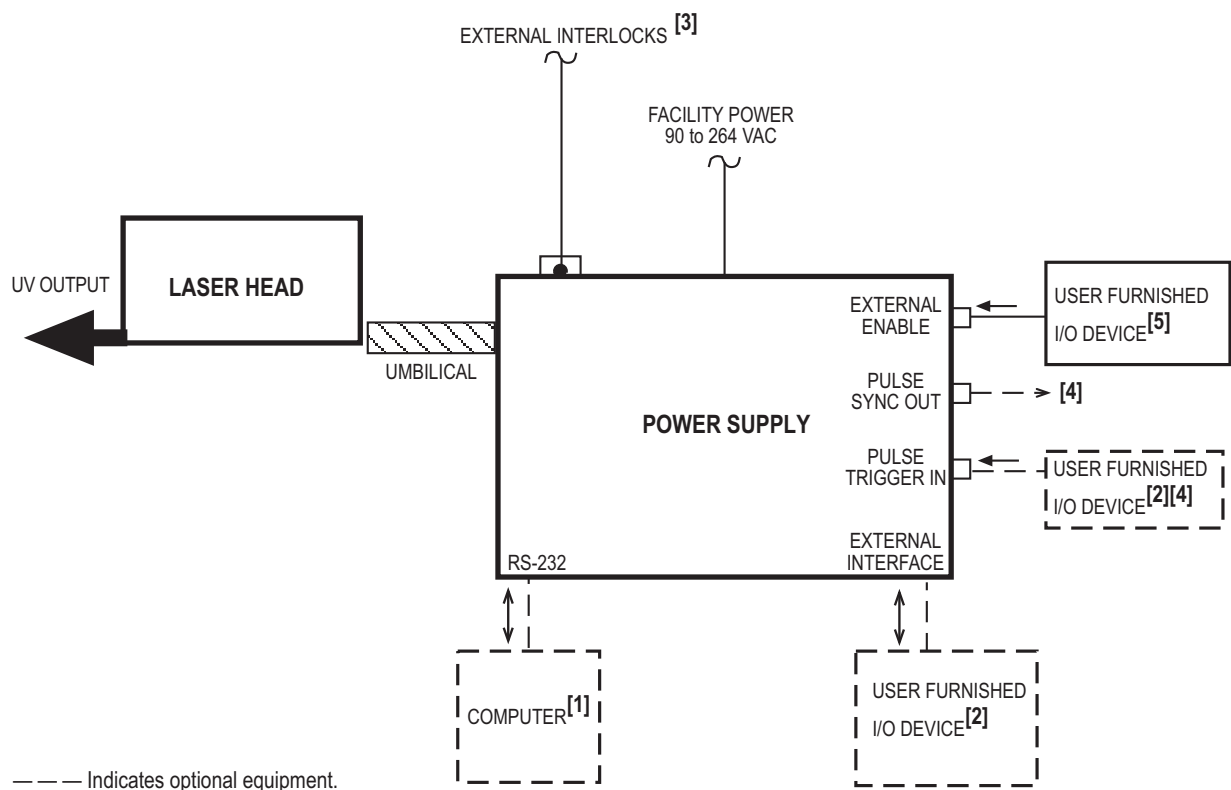

- [1] A computer connected to the RS-232 port uses a DB-8 connector shown in Figure 5 with the setup described in Table 10.
- [2] User furnished equipment capable of sending and receiving TTL level signals. Refer to Table 5.
- [3] Refer to Table 4 for the interlock connector pinouts.
- [4] Refer to Table 6.
- [5] Refer to Table 6. If user furnished device is not connected here or at external interface, the connector supplied with the system must be installed.

Figure 1. Interconnection Diagram

Umbilical Bend Radius

Ensure the umbilical has a bend radius of 5 inches or greater.



Excessively tight fiber bends (less than a 5 inch radius) can cause permanent damage.

Installation Procedures

After installing the laser head and power supply in accordance with paragraphs titled, Installing the Laser Head, and Installing the Power Supply, complete the installation as follows:

1. Connect power supply to facility power.
2. Perform the cold start procedure located in Section Three, Operation, within the operator's manual.

Table 1. Utility Requirements

PARAMETER	REQUIREMENT
AC Voltage Requirements	100 to 240 VAC ^[1] , 47-63 Hz
Maximum Current	10 Amps @ 115 VAC 5 Amps @ 230 VAC
Cooling: Laser head: Power supply:	Conductive to baseplate Air cooled with ambient air
Note: All specifications and requirements are subject to change without notice.	
[1] The power supply is autoranging and will accommodate the input voltages of 90 to 264 VAC without hardware changes.	

Table 2. Environmental Requirements

PARAMETER	REQUIREMENT
Ambient operating temperature	10°C to 35°C (50 to 95°F) ^[1] Water cooled base plate required for 355-7000 and 355-X
Relative humidity	5 to 90% (non-condensing)
Altitude	Sea level to 10,000 feet (3,000 m)
Note: All specifications and requirements are subject to change without notice.	
[1] AVIA 355-X air-cooled power supply is limited to maximum 30°C ambient air temperature	

Table 3. Dimensions and Weights

	POWER SUPPLY	LASER HEAD	UMBILICAL
LENGTH	45.2 cm (17.8 in)	AVIA 76.2 cm (30.0 in) AVIA-X 79.9 cm (31.4 in)	3 meters (10 feet)
WIDTH	43.4 cm (17.1 in)	20.3 cm (8.0 in)	— —
HEIGHT	25.4 cm (10.0 in)	19.5 cm (7.7 in)	— —
WEIGHT	38.6 kg (85 lbs)	AVIA 21.8 kg (48 lbs) AVIA-X 25.4 kg (56 lbs)	2.7 kg (6 lbs)
DIAMETER	— —	— —	3.75 cm (1.5 in)

POWER SUPPLY - FRONT VIEW

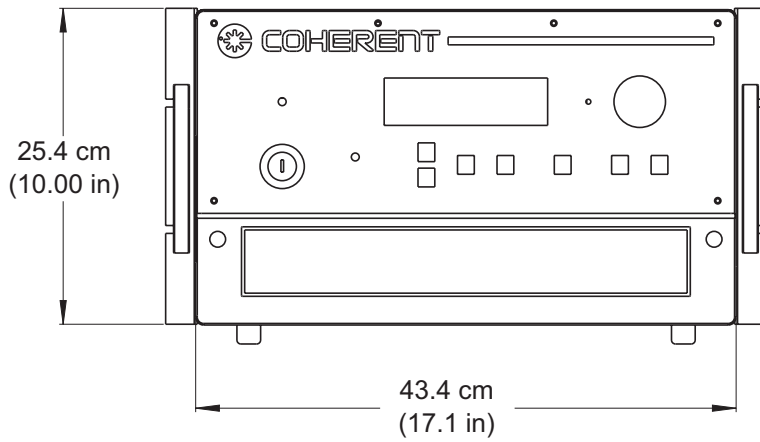

POWER SUPPLY - BACK VIEW

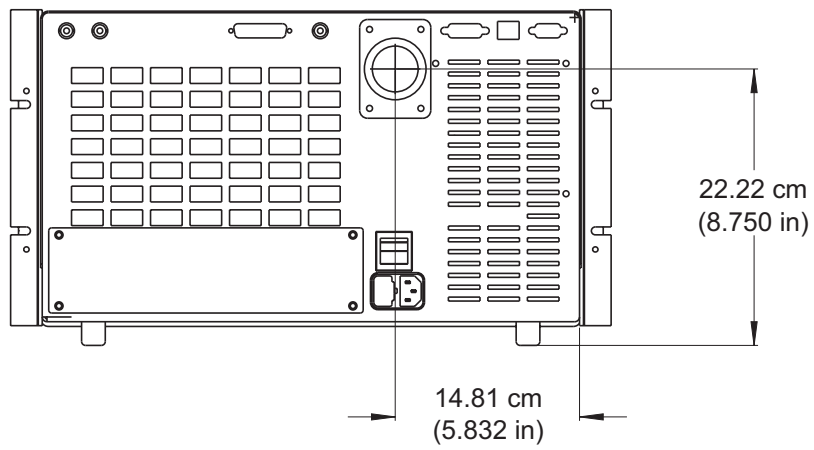

POWER SUPPLY - SIDE VIEW

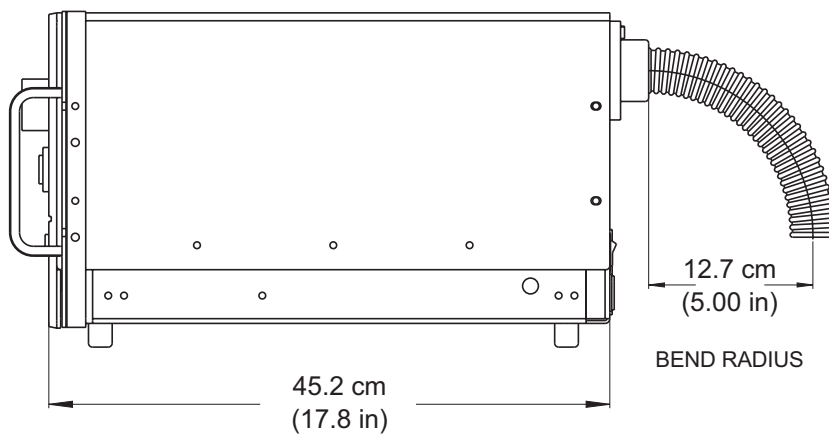
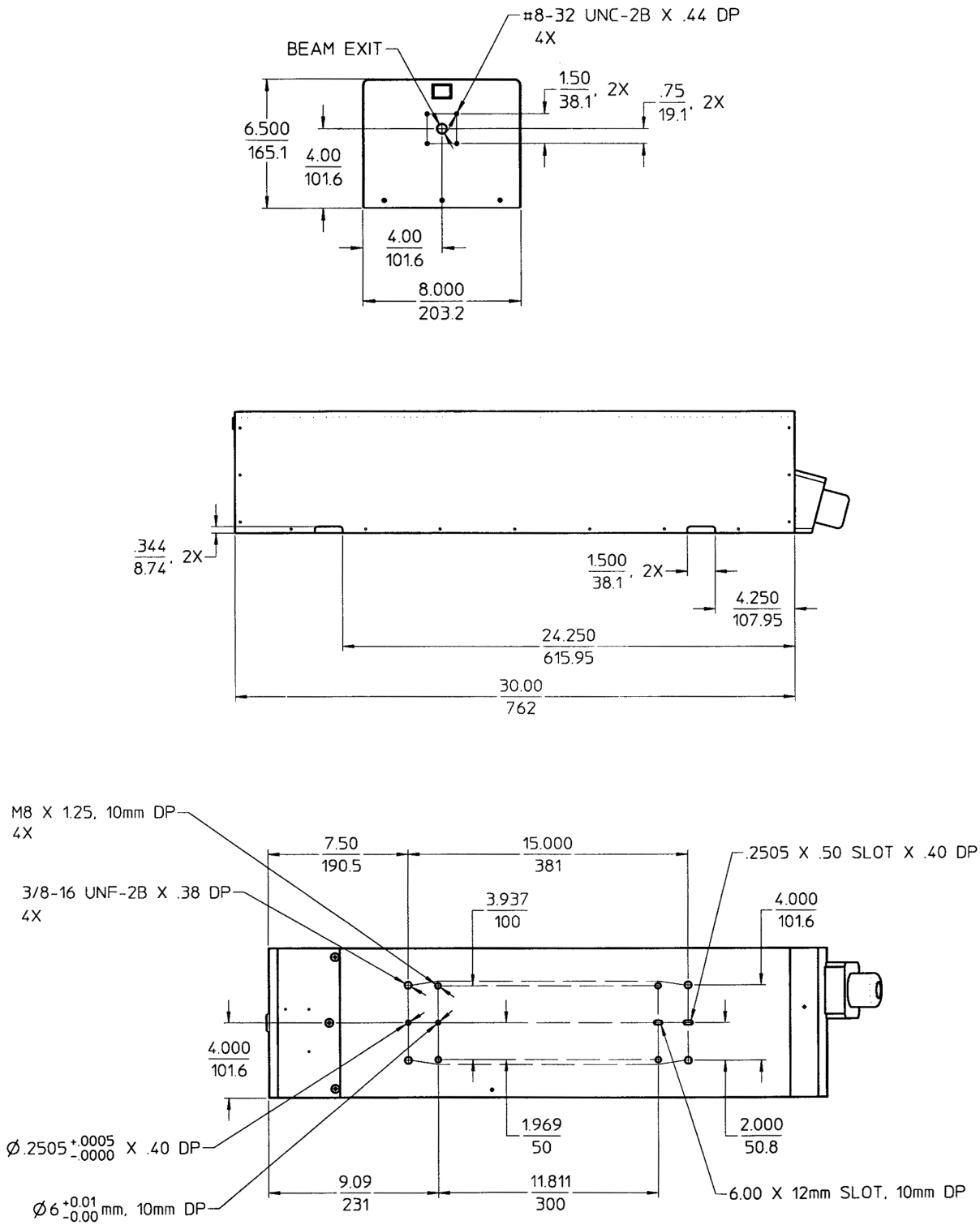

Figure 2. Power Supply Dimensions (with Rack Mount - Optional)



AVIA 355-3000, 355-4500, AND 355-7000

Figure 3. AVIA Laser Head Dimensions

Table 4. EXTERNAL INTERLOCK/CHILLER Connector Pinouts

THIS CONNECTOR IS A DA-15 PIN FEMALE (PLUG WITH SOCKETS) CONNECTOR.

PIN	DESCRIPTION	FUNCTION
1	Emission lamp relay contact	Output signal (pins 1 and 2) used to determine the Laser Emission Lamp status. Also refer to note 1. Normally closed contact is shorted to common when laser emission lamp is Off. Do not exceed 30 V or 1 A.
2	Emission lamp relay contact	Common for pins 1 and 3.
3	Emission lamp relay contact	Output signal (pins 3 and 2) used to determine Laser Emission Lamp status. Also refer to note 1. Normally open contact is shorted to common when laser emission lamp is On. Do not exceed 30 V or 1 A.
4	Shutter interlock	Input for shutter interlock. A short between pins 4 and 5 allows the shutter to operate normally while an open prevents the shutter from being open. Impedance of the short must be less than 20 ohms. Impedance of the open must be greater than 5K ohms. Current through a short will be 20 mA typically.
5	Shutter interlock	Refer to pin 4.
6	Do not use	
7	Do not use	
8	Do not use	
9	External interlock	Input signal for external interlock. A short (less than 500 ohms) between pins 9 and 10 allows normal operation while an open (greater than 60K ohms) prevents laser emission.
10	External interlock	Refer to pin 9.
11	Not used	— —
12	Not used	— —
13	Do not use	
14	Do not use	
15	Do not use	
1. Pins 1, 2, and 3 are isolated from system.		

Table 5. EXTERNAL INTERFACE Connector Pinouts

THIS CONNECTOR IS A DB-25 PIN FEMALE (PLUG WITH SOCKETS) CONNECTOR.

PIN	DESCRIPTION	FUNCTION
1	Analog Ground	Analog signal ground reference (do not use).
2	Analog Input 1	0 to +5 V. (DO NOT USE)
3	Analog Input 2	0 to +5 V. (DO NOT USE)
4	Not Used	— —
5	Not Used	— —
6	Not Used	— —
7	Not Used	— —
8	External Enable	Input signal that enables pulsing. Apply more than 3.0 V referenced to pin 9 to enable pulsing. Leave open or apply less than 1.0 V referenced to pin 9 to disable pulsing. Do not exceed ± 10 V across pin 8 and 9. Input current will be less than 13 mA. Note that there is another external enable input available at a BNC connector on the rear panel. Either driving pins 8 and 9 or the BNC will enable pulsing. See Table 6. This input is not active in Internal Front Panel Trigger mode.
9	External Enable	Refer to pin 8.
10	Shutter State	Output signal indicating shutter status. The output is an optocoupler that conducts when the shutter is open. Positive current flows into pin 10 and out pin 11. Minimum optocoupler current is 2 mA at 0.6 V when asserted. Maximum current is 0.4 μ A at 5 V when off. Do not exceed ± 10 V across pins 10 and 11. When the shutter is open, the laser beam is allowed to exit the laser. A closed shutter blocks the beam.
11	Shutter State	Refer to pin 10.
12	Shutter Command	Input signal that opens and closes the shutter. Apply more than 3.0 V referenced to pin 13 to close the shutter. Leave open or apply less than 1.0 V to open the shutter. Do not exceed ± 10 V across pins 12 and 13. Input current will less than 13 mA.
13	Shutter Command	Refer to pin 12.
14	Analog Output	0 to +5 V, 5 mA. (DO NOT USE)
15	Analog Ground	Analog signal ground reference. (DO NOT USE)
16	Not used	— —
17	RF Ramp Status	Output signal is high during time the RF level is ramping down. Output goes low at the end of the ramp down period. When high, the output level is greater than 4.0V at 20mA referenced to pin 18. The low level output is less than 0.5V at 20mA.

Table 5. EXTERNAL INTERFACE Connector Pinouts (Continued)

PIN	DESCRIPTION	FUNCTION
18	Digital Ground	Digital ground reference for pin 17. This ground is connected to the chassis.
19	Not used	— —
20	Pulse Trigger In	Input signal that triggers the Q-Switch and produces a laser pulse. Apply more than 3.0 V referenced to pin 21 for a high level signal. Open circuit or apply less than 1.0 V for a low level signal. Pulses are triggered on the low to high transition. Input current will be less than 13 mA. Do not exceed ± 10 V across pins 20 and 21.
21	Pulse Trigger In	Refer to pin 20.
22	Alert	Output signal indicating a fault condition. The output is an optocoupler that conducts from pin 22 to pin 23 when there is an alert. Minimum optocoupler current is 2 mA at 0.6 V when asserted. Maximum current is 0.4 uA at 5 V when off. Do not exceed ± 10 V across pins 22 and 23.
23	Alert	Refer to pin 22.
24	Reset Fault	Input signal to acknowledge cleared faults. Apply more than 3.0 V referenced to pin 25 for a high level signal. Open circuit or apply less than 1.0 V for a low level signal. A low to high transition will acknowledge the faults. The laser will shut down in the event of a fault. When the fault is cleared (not active), the fault must be acknowledged, either through pins 24 and 25 or on the front panel, before diode current and pulsing can be again enabled.
25	Reset Fault	Refer to pin 24.

Table 6. BNC Connectors

DESCRIPTION	FUNCTION
Pulse Trigger In	The rising edge TTL input will trigger a laser pulse (See Section Three, Operation, within the operator's manual for details). Note that this is an alternate to DB 25 pins 20 and 21
Pulse Sync Out	TTL low output signal synchronous with the laser pulses.
External Enable	Active low TTL input. If the signal is disconnected or pulled high no laser pulsing can take place except in Front Panel Trigger mode.

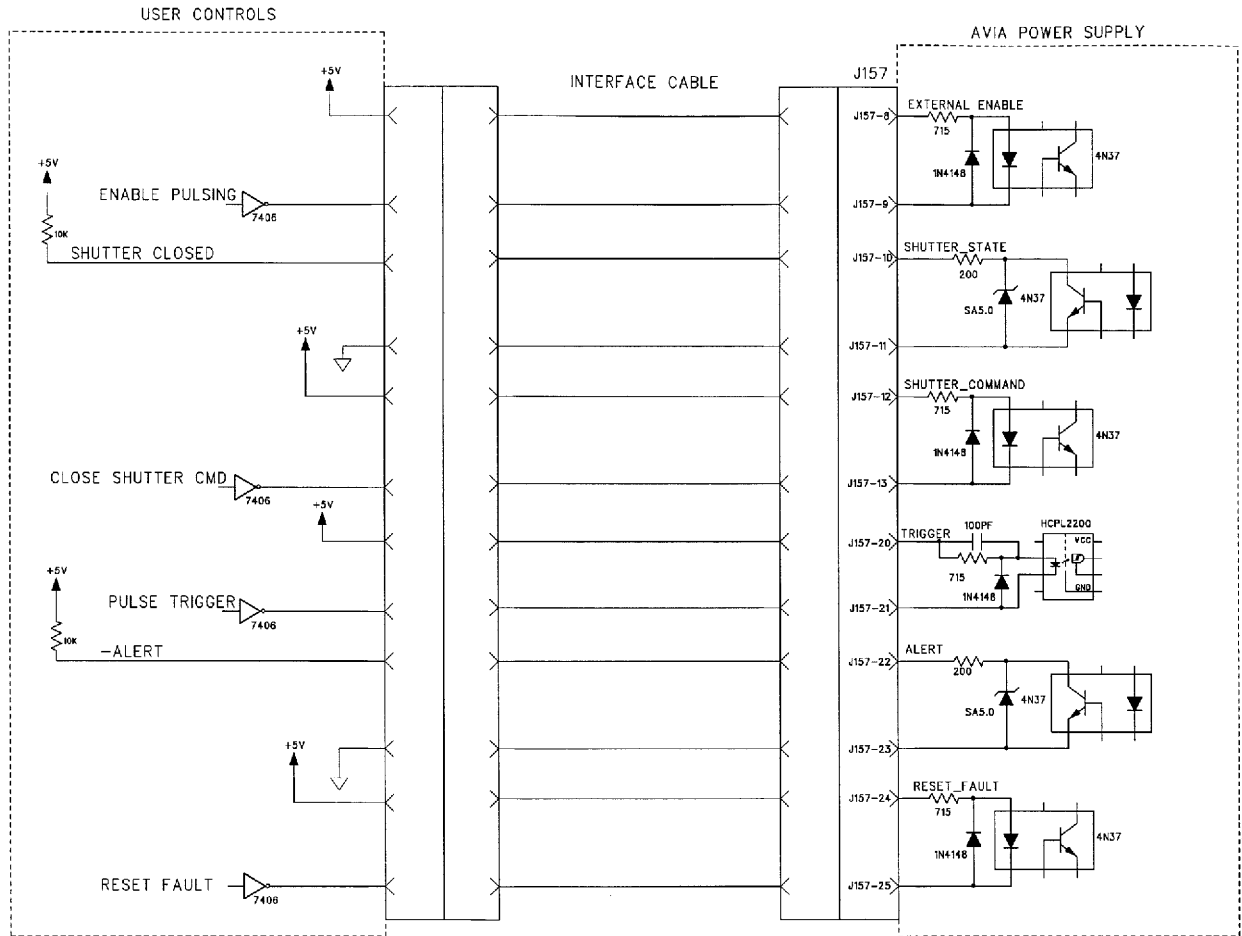

Figure 4. AVIA External Interface

Table 7. Suggested Mating Connectors to Interface with the AVIA Laser System

CONNECTORS ON POWER SUPPLY		MATING CONNECTORS (SUPPLIED BY USER)	
CONNECTOR NAME	CONNECTOR TYPE	MANUFACTURER	PART NUMBER
Pulse Trigger In	BNC (Jack)	Amphenol	9350
External Enable	BNC (Jack)	Amphenol	9350
Pulse Sync Out	BNC (Jack)	Amphenol	9350
External Interface	DB-25S	ITT Cannon	DBU25P (Note 1)
Interlock/Chiller	DA-15S	ITT Cannon	DAU15P (Note 1)
RS-232	DE-9S	ITT Cannon	DEU9P (Note 1)
Mains	IEC-320 C-14	Mating Power Cable Supplied	
Remote		Contact Factory	

1. Connectors listed include crimp pins, but not backshells, jack screws, or other accessories.
2. Equivalent connectors from any manufacturer are acceptable.

Table 8. Maximum Input Voltage/Current

CONNECTOR	PIN	DESCRIPTION	RATING	
Interlock	1	Emission relay NC	1 A, 30 V referenced to chassis or pin 2	
	2	Emission relay COM	1 A, 30 V referenced to chassis	
	3	Emission relay NO	1 A, 30 V referenced to chassis or pin 2	
	4	Shutter Interlock	±25 mA	
	5	Shutter Interlock	+15 V to -0.2 V referenced to chassis	
	9	External Interlock	+5 V to -10 V referenced to chassis	
	10	External Interlock	±4 mA	
	RS-232	2	TXD	±30 mA
		3	RXD	±25 V referenced to chassis
	Ext Interface	2	Analog In 1	0 to +5 V referenced to chassis
3		Analog In 2	0 to +5 V referenced to chassis	
8		Isolated enable	±10 V referenced to pin 9. ±42 V referenced to chassis	
9		Isolated enable	±10 V referenced to pin 8. ±42 V referenced to chassis	
10		Shutter state	±10 V referenced to pin 11. ±42 V referenced to chassis	
11		Shutter state	±10 V referenced to pin 10. ±42 V referenced to chassis	
12		Shutter command	±10 V referenced to pin 13. ±42 V referenced to chassis	
13		Shutter command	±10 V referenced to pin 12. ±42 V referenced to chassis	
14		Analog out	±10 mA	
17		RF Ramp Status	-0.5 to +5.5, ±20 mA referenced to pin 18 or the chassis.	
20		Pulse trigger	±10 V referenced to pin 21. ±42 V referenced to chassis	
21		Pulse trigger	±10 V referenced to pin 20. ±42 V referenced to chassis	
22		Alert	±10 V referenced to pin 23. ±42 V referenced to chassis	
23		Alert	±10 V referenced to pin 22. ±42 V referenced to chassis	
24	Reset fault	±10 V referenced to pin 25. ±42 V referenced to chassis		
25	Reset fault	±10 V referenced to pin 24. ±42 V referenced to chassis		
Pulse sync out			+60 mA to -100 mA output current	
Pulse Trigger in			-0.2 V to 5.25 V referenced to chassis ground	
Pulse gate in			-0.2 V to 5.25 V referenced to chassis ground	
Do not apply hazardous or potentially hazardous voltages to any of the control communications ports of the AVIA power supply. Do not exceed the maximum input voltages listed in this table.				

EXTERNAL COMPUTER CONTROL

AVIA Computer Interface

This section provides information on interfacing the AVIA 355 laser to an external computer through the RS-232 connector on the rear of the power supply.

The RS-232 interface is based on a set of laser control instructions, consisting of commands that affect laser operation, and queries that request the laser to return status information to the host. The instruction set is sufficient to support user-written programs that emulate the functions of the power supply front panel.

RS-232 Command Language

RS-232 Command Syntax

Communication with the AVIA 355 is by two types of instructions: commands which set the values of laser operating parameters, and queries which request the laser to return the value of an operating parameter.

Any instruction to the laser consists of a command or query written as a string of ASCII characters and terminated by a carriage return and linefeed (<CR>) or a semicolon (;).

For example:

REPRATE=nnnnn<CR> Sets the repetition rate in Hz.

The laser will always respond to an instruction by returning a message terminated by a carriage return and linefeed. Table 9 lists the possible responses from the laser.



For proper handshaking, communication programs should wait until the <CR><LF> has been returned from the laser before sending the next instruction.

Table 9. Response from Laser after Receiving Instruction

INSTRUCTION SENT TO LASER	RESPONSE FROM LASER	
	ECHO OFF PROMPT OFF	ECHO ON PROMPT OFF
Command + <CR>	<CR><LF>	Command + <CR><LF>
Query + <CR>	Data ^[1] + <CR><LF>	Query + Data ^[1] + <CR><LF>
Command + <CR> (illegal operand)	Out of Range + <CR><LF>	Command + Out of Range + <CR><LF>
Command or Query + <CR> (illegal instruction)	Syntax Error: Command or Query + <CR><LF>	Command or Query + Syntax Error: Command or Query + <CR><LF>
[1] Multiple items will be separated by the & character. For example, a list of system faults will be returned as 3&5&6.		

ECHO Mode

The AVIA 355 provides an echo mode in which each character transmitted to the laser is echoed to the host. This feature can be turned on or off using the ECHO command (refer to Table 11).

PROMPT Mode

The AVIA 355 provides an prompt mode for terminal operation in which the laser returns “AVIA>” after each command. This feature can be turned on or off using the PROMPT command (refer to Table 11).

? or Print

The single character ? may be substituted for **PRINT** in all queries. For example:

?SHUTTER is equivalent to **PRINT SHUTTER**.

Characters = or :

The single characters = and : are equivalent delimiters between text and data in all commands. For example:

ECHO=0 is equivalent to **ECHO:0**

RS-232 Port Configuration

The RS-232 port configuration is described in Table 10, and typical cable requirements are shown on Figure 5. The 9-pin female RS-232 port is configured as a DCE (data communications equipment) device using only pins 2 (serial data out), 3 (serial data in) and 5 (signal ground). Handshake lines RTS, CTS, DTR and DSR (pins 4, 6, 7 and 8) are not used and have no connections inside the power supply.

Table 10. RS-232 Port Description

CONFIGURATION	DCE, NO HANDSHAKING
Data bits	8
Stop bits	1
Parity	none
Baud rate	User selectable: 1200 4800 9600 19200 (default factory setting) 38400 57600

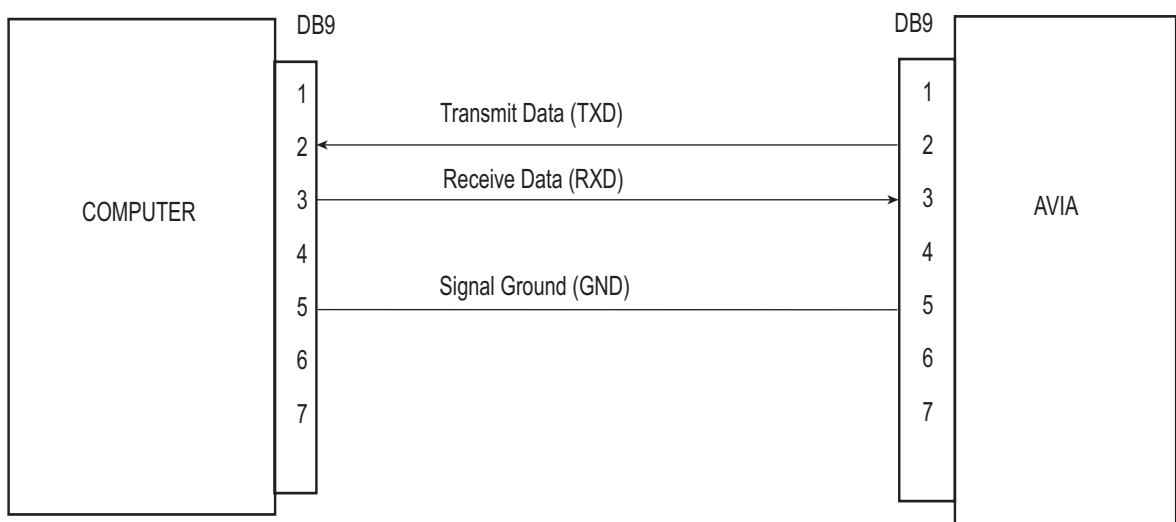

Figure 5. RS-232 Pin Configuration

Setting the Baud Rate

The baud rate of the 9-pin RS-232 port can be changed by means of the **BAUDRATE=NNN** command described in Table 11. After the baud rate is changed, the new setting will be used until it is changed (even if the system power is switched off).

To set the baud rate from an external computer, send the **BAUDRATE=nnnnn** command to the laser at the currently set baud rate. After sending this baudrate command, host computer communications port must be reinitialized to the new baudrate.

The baud rate can also be set from the front panel screen labeled RS-232 Baud Rate Setup. Follow instructions on the screen to change the baud rate.

The factory set baud rate is 19200.

Instruction Set

Table 11 and Table 12 describe the instructions (long and short forms) for use with the RS-232 interface.

Table 11. RS-232 Commands

COMMANDS	ACTION PERFORMED
BAUDRATE=nnnnn B=nnnnn	Sets the RS-232 Serial port baud rate to the specified value. nnnnn = 1200, 2400, 4800, 9600, 19200, 38400, 57600
BURST MODE BM=n	n=0 Continuous n=1 Pulsed
BURST PULSES=nnnnnn BP=nnnnnn	Sets the number of pulses in a burst. Allowed range is 1 to 255 pulses.
CURRENT=nn.n C=nn.n	Sets the diode current to nn.n percentage from 0.1% (10 Amps) to 100% (maximum allowable current). A setting of 0% will be zero current. Allowable range is 0 – 100 in 0.1% increments.
DIODE ON=n DO=n	Turns the diode current on or off. n = 0 is diode current off. n = 1 is diode current on.
DIODE1 OPTIMIZE=n D1O=n	Initiates the diode 1 temperature optimization routine. n = 0 aborts optimization. n = 1 initiates optimization. (available only in continuous mode, internal trigger).
DIODE1 TEMP=nn.nn D1T=nn.nn	Closes servo and sets laser diode 1 temperature in degrees Centigrade. The allowed temperature range is 10.00 to 40.00°C.

Table 11. RS-232 Commands (Continued)

COMMANDS	ACTION PERFORMED
DIODE2 OPTIMIZE=n D2O=n	Initiates the diode 2 temperature optimization routine. n = 0 aborts optimization. n = 1 initiates optimization. (available only in continuous mode, internal trigger only).
DIODE2 TEMP=nn.nn D2T=nn.nn	Closes servo and sets laser diode 2 temperature in degrees Centigrade. The allowed temperature range is 10.00 to 40.00°C.
DIOPTRIC OPTIMIZE POWER=n DOP=n	Initiates the ThermaTrack peaking routine. n = 1 initiates ThermaTrack peaking. (available only in continuous mode, internal trigger only).
ECHO=n E=n	If n = 0 turns off echo. Characters transmitted to the laser will not be echoed. If n = 1 turns on echo. Characters transmitted to the laser will be echoed. A change in echo mode will take effect with the first command sent after the echo command.
EXIT SCREEN=n EXIT=n	n=1 clears the display screen fault message; same as pushing the Menu Exit PB.
LOCK OUT FRONT PANEL=n LF=n	Locks out front panel controls. n = 0 Front panel controls are active. n = 1 Front panel controls are locked out.
LOCK POWER=n LP=n	Initiates power lock. If n = 0 system begins current lock. If n = 1 system begins power lock. (available only in continuous mode, internal trigger).
MOVE D MOTOR=nnnn MD=nnnn	Moves the ThermaTrack adjust motor to the nnnn step position. Range is 0 to 6150.
PROMPT=n >=n	If n = 0 turns off "AVIA>" prompt. If n = 1 turns on "AVIA>" prompt.
PULSE CONTROL=n PC=n	Starts and stops the q-switch pulses. n = 0 is pulsing off. n = 1 is pulsing on.
SET PULSE ENERGY ON=n PEON=n	n = 0 Pulse energy off (100%). n = 1 Pulse energy on.
PULSE ENERGY PERCENT=n PEP=n	n = Set energy percent.

Table 11. RS-232 Commands (Continued)

COMMANDS	ACTION PERFORMED
PULSE MODE=n PM=n	Sets the pulse mode. n = 0 in continuous mode. n = 1 is burst mode. n = 2 is CW alignment mode.
REPRATE=nnnnnn RR=nnnnnn	Sets the repetition rate in Hz. Allowable values: 3 to 300000 Hz.
RESET SYSTEM=1 RESET=1	Stops the internal watchdog timer and causes the system to reboot. Use this command only when necessary.
SET CRYSTAL WARNING INTERVAL CWI=nnnn	Sets the warning time interval for each crystal spot in hours (10 to 1000 hours). Default is 100 hours.
SET SPOT POSITION=± SP=±	Sets the current crystal shifter spot position to the next spot or the last spot. SP=+ is next spot. SP=- is previous spot.
SET SPOT STATUS:nn=x SPS:n=x Spots 1-9 SPS:nn=x Spots 10-99	Changes the status of THG crystal spots between GOOD and USED. nn= The spot number of the THG crystal spot you wish to change. x=0 Sets the status to GOOD x=1 Sets the status to USED
SHG HEATER=n SHGH=n	If n = 0 turns off SHG heater (COOLDOWN). If n = 1 turns on SHG heater (HEATING).
SHG OPTIMIZE=n SHGO=n	Initiates the SHG temperature optimization routine. n = 0 aborts optimization. n = 1 initiates optimization. (available only in continuous mode, internal trigger).
SHG TEMP=nnn.nn SHGT=nnn.nn	Closes servo and sets the SHG temperature in degrees Centigrade. The temperature setting is allowed up to approximately 170.00°C.
SHUTTER=n S=n	If n = 0 closes external shutter. If n = 1 opens external shutter.
THG FINE OPTIMIZE=n THGFO=n	Turns the fine optimization routine on or off. If n = 0 turns optimizer off. If n = 1 turns optimizer on.
THG OPTIMIZE=n THGO=n	Initiates the course THG temperature optimization routine. n = 0 aborts optimization. n = 1 initiates optimization. (available only in continuous mode, internal trigger)
THG TEMP=nn.nn THGT=nn.nn	Closes servo and sets the THG temperature in degrees Centigrade. The temperature setting is allowed up to approximately 70°C.

Table 11. RS-232 Commands (Continued)

COMMANDS	ACTION PERFORMED
TRIGGER MODE=n TM=n	Sets the trigger mode to internal or external. If n = 0, mode is internal. If n = 1, mode is external. If n = 2, mode is front panel.
FOLLOWING COMMANDS ARE FOR PULSE DELETE AND THERMEQ FUNCTIONS:	
PULSE DELETE=n PD=n	This command changes the PULSE CONTROL mode of operation and is NOT recommended for AVIA 266. n=1 Pulse Delete On n=2 ThermEQ On n=3 PulseEQ On n=4 PulseTrack On
PULSE DELETE AUTO CALCULATE=n PDAC=n	Controls whether timing calculations for delay time are changed with internal repetition rate setting. Note that for automatic settings, times will not change until a change of PRF is made. n=0 for manual. n=1 for automatic.
DELAY TIME=nn DT=nn	Sets the Pulse Delete RePumpTime (DT1) in microseconds while in the Pulse Delete mode (MODE1) of operation. Sets the ThermEQ Delay Time (DT2) in microseconds while in the ThermEQ, PulseEQ, and PulseTrack modes (MODE2) of operation. Valid range is 0 to 200 us.
MODE1 DELAY TIME=nn DT1=nn	Sets the RePumpTime (DT1) in microseconds for the Pulse Delete mode (MODE1) of operation. Note that in Pulse Delete mode, this command is redundant to the DT=nn command. Valid range is 0 to 200 us.
MODE2 DELAY TIME=nn DT2=nn	Sets the Delay Time (DT2) in microseconds for the ThermEQ, PulseEQ, and PulseTrack modes (MODE2) of operation. Note that in ThermEQ, PulseEQ, and PulseTrack modes, this command is redundant to the DT=nn command. Valid range is 0 to 200 us.

Table 12. RS-232 Queries

QUERIES	RETURNED INFORMATION
PRINT AVG CURRENT AND DELTA ?ACAD	Prints the average diode current and the current difference between diode 1 and diode 2.
PRINT BASEPLATE TEMP ?BT	Returns laser head baseplate measured temperature in °C.
PRINT BAT VOLTS ?BV	Returns the measured voltage across the battery, nn.nn, in volts.
PRINT BURST MODE ?BM	Returns Burst Mode operation: 0 = Continuous 1 = Pulsed
PRINT BURST PULSES ?BP	Returns the number of pulses in a burst. Number of pulses is 1 to 255.
PRINT CRYSTAL WARNING ELAPSED ?CWE	Returns the number of hours until the next warning.
PRINT CRYSTAL WARNING INTERVAL ?CWI	Returns warning time interval for each crystal spot in hours. Once crystal warning interval has expired, the crystal spot number will appear (via RS-232) followed by a comma and the amount of spot hours.
PRINT CURRENT DELTA ?CD	Returns the diode current delta calibration in amps.
PRINT CURRENT MAXIMUM ?CMAX	Returns the calculated 100% average current maximum in Amps nn.nn.
PRINT CURRENT PERCENTAGE ?CPT	Returns the current as a percentage nn.n.
PRINT CURRENT ?C	Returns the average diode current in amps.
PRINT D MOTOR POSITION ?MD	Returns the motor position for the ThermaTrack motor.
PRINT DIODE ON ?DO	Returns the state of the diodes 0 if diode current is off. 1 if diode current is on.
PRINT DIODE1 CURRENT DRIVE ?D1CD	Returns diode 1 current drive.
PRINT DIODE1 CURRENT ?D1C	Returns laser diode 1 current in amps.
PRINT DIODE1 HEATSINK TEMP ?D1HST	Returns laser diode 1 heat sink measured temperature in °C.

Table 12. RS-232 Queries (Continued)

QUERIES	RETURNED INFORMATION
PRINT DIODE1 HOURS ?D1H	Returns the number of operating hours on laser diode 1.
PRINT DIODE1 OPTIMIZE ?D1O	Returns the status of the diode 1 optimization power routine. 1 means the system is optimizing.
PRINT DIODE1 PHOTOCELL ?D1PC	Returns a voltage that is a measure of the FAP-I diode 1 power at the 100% current setting. If the correct voltage is returned, then the diode is good. If any other voltage, higher or lower, is returned, then either: (a) actual diode 1 power should be measured to confirm the diagnostic value, or (b) diode 1 should be replaced.
PRINT DIODE1 RATED CURRENT FACTOR ?D1RCF	Returns the degradation rate of diode 1 per 1000 hours as n.n. n.n=0.01 is 1% increase in maximum current per 1000 hours.
PRINT DIODE1 RATED CURRENT MAX ?D1RCM	Returns the calculated 100% current of diode 1 in Amps as nn.nn. This value is the set maximum current plus the increase in rated current as calculated by the diode 1 degradation rate and diode 1 hours.
PRINT DIODE1 RATED CURRENT ?D1RC	Returns the set maximum current of diode 1 in Amps as nn.nn.
PRINT DIODE1 SERVO STATUS ?D1SS	Returns the status of diode 1 temperature servo: 0 if the servo is OPEN. 1 if the servo is LOCKED. 2 if the servo is SEEKING. 3 if the servo has a FAULT. 4 if the servo is OPTIMIZING.
PRINT DIODE1 SET TEMP ?D1ST	Returns laser diode 1 set temperature in °C.
PRINT DIODE1 TEMP DRIVE ?D1TD	Returns diode 1 temperature servo drive setting.
PRINT DIODE1 TEMP ?D1T	Returns laser diode 1 measured temperature in °C.
PRINT DIODE1 VOLTAGE ?D1V	Returns the measured voltage across diode 1 in volts as n.n.
PRINT DIODE2 CURRENT DRIVE ?D2CD	Returns diode 2 current drive.
PRINT DIODE2 CURRENT ?D2C	Returns laser diode 2 current in amps.
PRINT DIODE2 HEATSINK TEMP ?D2HST	Returns laser diode 2 heat sink measured temperature in °C.

Table 12. RS-232 Queries (Continued)

QUERIES	RETURNED INFORMATION
PRINT DIODE2 HOURS ?D2H	Returns the number of operating hours on laser diode 2.
PRINT DIODE2 OPTIMIZE ?D2O	Returns the status of the diode 2 optimization power routine. 1 means the system is optimizing.
PRINT DIODE2 PHOTOCELL ?D2PC	Returns a voltage that is a measure of the FAP-I diode 2 power at the 100% current setting. If the correct voltage is returned, then the diode is good. If any other voltage, higher or lower, is returned, then either: (a) actual diode 2 power should be measured to confirm the diagnostic value, or (b) diode 2 should be replaced.
PRINT DIODE2 RATED CURRENT FACTOR ?D2RCF	Returns the degradation rate of diode 2 per 1000 hours as n.n. n.n=0.01 is 1% increase in maximum current per 1000 hours.
PRINT DIODE2 RATED CURRENT MAX ?D2RCM	Returns the calculated 100% current of diode 2 in Amps as nn.nn. This value is the set maximum current plus the increase in rated current as calculated by the diode 2 degradation rate and diode 2 hours.
PRINT DIODE2 RATED CURRENT ?D2RC	Returns the set maximum current of diode 2 in Amps as nn.nn.
PRINT DIODE2 SERVO STATUS ?D2SS	Returns the status of diode 2 temperature servo: 0 if the servo is OPEN. 1 if the servo is LOCKED. 2 if the servo is SEEKING. 3 if the servo has a FAULT. 4 if the servo is OPTIMIZING.
PRINT DIODE2 SET TEMP ?D2ST	Returns laser diode 2 set temperature in °C.
PRINT DIODE2 TEMP DRIVE ?D2TD	Returns diode 2 temperature servo drive setting.
PRINT DIODE2 TEMP ?D2T	Returns laser diode 2 measured temperature in °C.
PRINT DIODE2 VOLTAGE ?D2V	Returns the measured voltage across diode 2 in volts as n.n.
PRINT DIOPTRIC MOTOR MOVING ?DMM	Returns 0 if motor is not moving Returns 1 if motor is moving
PRINT DIOPTRIC OPTIMIZE POWER ?DOP	Returns the status of the ThermoTrack optimization power routine. 1 means the system is optimizing.
PRINT EEPROM:nn ?EE:nn	Returns the value of the EEPROM location at Index nn.

Table 12. RS-232 Queries (Continued)

QUERIES	RETURNED INFORMATION
PRINT FAULT HISTORY ?FH	Returns a list of number codes (see ?F) of all faults that have occurred since the last EXIT SCREEN command, separated by an &, or return "System OK" if no latched faults. The EXIT SCREEN command or the EXIT button on the power supply when the fault screen is active will clear the fault history and fault screen.
PRINT FAULTS ?F	Returns a list of number codes of all active faults, separated by an &, or returns "System OK" if no active faults. Fault codes: 1=Emission Indicator Fault, 21=Diode 1 Over Volt Fault, 2=External Interlock Fault, 22=Diode 2 Over Volt Fault, 3=PS Cover Interlock Fault, 23=N/A, 4=SHG Temp. Fault, 24=N/A, 5=N/A, 25=Diode 1 EEPROM Fault, 6=Laser Rods Temp. Fault, 26=Diode 2 EEPROM Fault, 7=THG Temp. Fault, 27=Laser Head EEPROM Fault, 8=Diode 1 Temp. Fault, 28=Power Supply EEPROM Fault, 9=Diode 2 Temp. Fault, 29=PS-Head Mismatch Fault, 10=Baseplate Temp. Fault, 30=SHG Battery Fault, 11=Heatsink 1 Temp. Fault, 31=Shutter State Mismatch Fault, 12=Heatsink 2 Temp. Fault, 32=Head Reset Fault, 13=N/A, 33=Head Communications Fault, 14=PS DC Voltage Fault, 34=Head Comm Out of Sync Fault, 15=PS AC Voltage Fault, 35=UART Hardware Fault, 16=N/A, 36=Power Lock Fault, 17=N/A, 37=Servo Temp Fault, 18=N/A, 38=Front Panel Switch Fault 19=Diode 1 Under Volt Fault, 39=Shutter Interlock Fault 20=Diode 2 Under Volt Fault,
PRINT HEAD HOURS ?HH	Returns the number of operating hours on the system head.
PRINT IR ENERGY ?IE	Returns the calibrated output IR pulse energy in microjoules. (Not Available for AVIA 355-X)
PRINT IR POWER ?IP	Returns the calibrated output IR average power in watts, or the word "External" if the system is in external trigger mode.
PRINT KEYSWITCH ?K	Returns 0 if the keyswitch is OFF. 1 if the keyswitch is ON.
PRINT LASER ROD DRIVE ?LRD	Returns laser rod temperature servo drive setting.

Table 12. RS-232 Queries (Continued)

QUERIES	RETURNED INFORMATION
PRINT LASER ROD SERVO STATUS ?LRSS	Returns the status of the laser rod temperature servo: 0 if the servo is OPEN. 1 if the servo is LOCKED. 2 if the servo is SEEKING. 3 if the servo has a FAULT.
PRINT LASER ROD SET TEMP ?LRST	Returns laser rod set temperature in °C.
PRINT LASER ROD TEMP ?LRT	Returns laser rod measured temperature in °C.
PRINT LOCK OUT FRONT PANEL ?LF	Returns the status of the front panel controls. 0 = front panel controls are active. 1 = front panel controls are locked out.
PRINT LOCK POWER ?LP	Returns the status of the system control. 0 = system is in current lock. 1 = system is in power lock.
PRINT OPMODE ?OP	Returns 0 if the laser is (STANDBY). 1 if the laser is in ON. 2 if the laser is in STANDBY because FAULT occurred (check faults or fault history).
PRINT PS HOURS ?PSH	Returns power supply operating hours.
PRINT PULSE CONTROL ?PC	Returns the status of the q-switch pulsing. 0 = pulsing off. 1 = pulsing on.
PRINT PULSE ENERGY ?PEON	Indicates whether Pulse Energy is on or off. 0 = off. 1 = on.
PRINT PULSE ENERGY PERCENT ?PEP	Indicates Pulse Energy percentage.
PRINT PULSE MODE ?PM	Returns the pulse mode. 0 is continuous mode. 1 is burst mode. 2 is CW alignment mode.
PRINT REPRATE ?RR	Returns the status of the pulse repetition rate setting, in Hz.

Table 12. RS-232 Queries (Continued)

QUERIES	RETURNED INFORMATION
PRINT RF LEVEL ?RL	Returns the RF percentage level. Range is 0 to 100%
PRINT RF STATE ?RF	Returns the state of the RF module. 0 is off. 1 is on.
PRINT SERVICE SWITCH ?SS	Returns the position of the service switch. 0 is user mode. 1 is service mode.
PRINT SHG DRIVE ?SHGD	Returns SHG temperature servo drive setting.
PRINT SHG HEATER ?SHGH	Returns the status of the SHG heater: 0 if the SHG heater is OFF (COOLDOWN). 1 if the SHG heater is ON (HEATING).
PRINT SHG OPTIMIZE ?SHGO	Returns the status of the SHG power optimization routine. 1 means the system is optimizing.
PRINT SHG SERVO STATUS ?SHGSS	Returns the status of the SHG temperature servo: 0 if the servo is OPEN. 1 if the servo is LOCKED. 2 if the servo is SEEKING. 3 if the servo has a FAULT. 4 if the servo is OPTIMIZING.
PRINT SHG SET TEMP ?SHGST	Returns SHG set temperature in °C.
PRINT SHG TEMP ?SHGT	Returns SHG measured temperature in °C.
PRINT SHUTTER ?S	Returns the status of the external shutter: 0 = shutter closed. 1 = shutter open.
PRINT SHUTTER INTERLOCK STATUS ?SIS	Returns the status of the shutter interlock sense: 0 = shutter interlock closed. 1 = shutter interlock open.
PRINT SPOT ?SP	Returns the current spot location on the THG crystal.
PRINT SPOT HOURS:n ?SPH:n	Returns hour value for specified crystal spot. n = crystal spot.

Table 12. RS-232 Queries (Continued)

QUERIES	RETURNED INFORMATION
PRINT SPOT STATUS:nn ?SPS:nn	nn= The spot number of the THG crystal spot you wish to check. 0 if the spot status is GOOD. 2 if the spot status is USED.
PRINT TEMP SERVO TIGHT LOCK STATUS ?TSTLS	Indicates is all temperature servos are within 0.1°C of set temperature. 0 = Not within 0.1°C 1 = within 0.1°C.
PRINT THG DRIVE ?THGD	Returns THG temperature servo drive setting.
PRINT THG FINE OPTIMIZE ?THGFO	Returns value of fine temp optimization routine.
PRINT THG OPTIMIZE ?THGO	Returns the status of the THG power optimization routine. 1 means the system is optimizing.
PRINT THG SERVO STATUS ?THGSS	Returns the status of the THG temperature servo: 0 if the servo is OPEN. 1 if the servo is LOCKED. 2 if the servo is SEEKING. 3 if the servo has a FAULT. 4 if the servo is OPTIMIZING. 5 if the servo is OPTIMIZING2 (Fine Optimizing) 6 if the servo is OPTIMIZING3 (Delay Fine Optimize until +/- 0.2°C.) 7 if the servo is OPTIMIZING4(State just before Fine Optimizing.)
PRINT THG SET TEMP ?THGST	Returns THG set temperature in °C.
PRINT THG TEMP ?THGT	Returns THG measured temperature in °C.
PRINT TRIGGER MODE ?TM	Returns the status of the trigger mode. 0 = internal trigger mode. 1 = external trigger mode. 2 = front panel trigger mode.
PRINT UV ENERGY ?UE	Returns the calibrated output UV pulse energy in microjoules.
PRINT UV POWER ?UP	Returns the calibrated output UV average power in watts, or the word “External” if the system is in external trigger mode.
PRINT X MOTOR POSITION ?MX	Returns the X motor position for the crystal shifter X motor.

Table 12. RS-232 Queries (Continued)

QUERIES	RETURNED INFORMATION
PRINT Y MOTOR POSITION ?MY	Returns the Y motor position for the crystal shifter Y motor.
FOLLOWING QUERIES ARE FOR PULSE DELETE AND THERMEQ FUNCTIONS:	
PRINT PULSE DELETE ?PD	Returns the PULSE CONTROL mode of operation. 1 = Pulse Delete On 2 = ThermEQ On 3 = PulseEQ On 4 = PulseTrack On
PRINT PULSE DELETE AUTO CALCULATE ?PDAC	Returns status of manual or automatic calculation of Delay Times: 0 for manual setting 1 for automatic setting
PRINT MAXIMUM RF ON TIME ?TOMAX	Returns maximum RF on time in microseconds. This time is the maximum time the RF can be on for any q-switched pulse in all modes of operation except Pulse Delete
PRINT MINIMUM RF OFF TIME ?TOMIN	Returns minimum RF off time in microseconds. This time is the minimum time the RF can be off while q-switching in Pulse Delete and ThermEQ modes
PRINT DELAY TIME ?DT	Returns the Delay Time in microseconds.
PRINT MODE1 DELAY TIME ?DT1	Returns the RePumpTime (DT1) in microseconds for the Pulse Delete mode (MODE1) of operation.
PRINT MODE2 DELAY TIME ?DT2	Returns the Delay Time (DT2) in microseconds for the ThermEQ, PulseEQ, and PulseTrack modes (MODE2) of operation.
PRINT DELAY TIME OFFSET ?DTO	Returns the Pulse Delete offset time (DTO1) in microseconds while in the Pulse Delete mode (MODE1) of operation. Returns the ThermEQ offset time (DTO2) in microseconds while in the ThermEQ, PulseEQ, and PulseTrack modes (MODE2) of operation.
PRINT MODE1 DELAY TIME OFFSET ?DTO1	Returns the Pulse Delete offset time (DTO1) in microseconds.
PRINT MODE2 DELAY TIME OFFSET ?DTO2	Returns the ThermEQ offset time (DTO2) in microseconds.
PRINT RAMP SLOPE ?RS	Returns the Ramp Slope (RS1) percentage for Pulse Delete while in the Pulse Delete mode (MODE1) of operation. Returns the Ramp Slope (RS2) percentage for ThermEQ while in the ThermEQ, PulseEQ, and PulseTrack modes (MODE2) of operation.

Table 12. RS-232 Queries (Continued)

QUERIES	RETURNED INFORMATION
PRINT MODE1 RAMP SLOPE ?RS1	Returns the Pulse Delete Ramp Slope percentage (RS1) for the Pulse Delete mode (MODE1) of operation.
PRINT MODE2 RAMP SLOPE ?RS2	Returns the ThermEQ Ramp Slope percentage (RS2) for the ThermEQ, PulseEQ, and PulseTrack modes (MODE2) of operation.
PRINT RAMP TIME OFFSET ?RTO	Returns the Ramp Time Offset in microseconds for the Pulse Delete function. This time is the default value (factory set value).
FOLLOWING QUERIES ARE FOR SERIAL NUMBER AND SOFTWARE VERSION:	
PRINT DIODE1 SERIAL NUMBER ?D1SN	Returns serial number of the FAPI module in Diode1 location.
PRINT DIODE2 SERIAL NUMBER ?D2SN	Returns serial number of the FAPI module in Diode2 location.
PRINT HEAD SERIAL NUMBER ?HSN	Returns serial number of the laser head.
PRINT HEAD SOFTWARE ?HSV	Returns firmware version of the laser head as HEAD rev x.xx, date.
PRINT POWER SUPPLY SERIAL NUMBER ?PSSN	Returns serial number of the power supply.
PRINT SOFTWARE ?SV	Returns firmware version of the power supply as P/S rev x.xx, date.

AVIA 355/AVIA 355-X Laser Preinstallation Manual
© Coherent, Inc. 06/2004, Printed in the U.S.A.
Part No. 0175-462-00, Rev FA